

Technical Data

Body / Chassis:

Full fiberglass body

Frame: Hot-dip galvanized AL-KO frame

Chassis: Braked AL-KO axle with V-drawbar chassis

Model:	Type S1	Type S2
Variant:	1300 (1500)	1500 (1800)
Length overall:	4780 mm	5205 mm
Length of body:	3610 mm	3970 mm
Width:	2080 mm	2480 mm
Height:	1970 mm	1990 mm
Net weight:	450 (460) kg	550 (570) kg
Gross weight:	1300 (1500) kg	1500 (1800) kg
Tyres:	205/70-14 (205/65-15)	205/65-15 (195/70-15)

Equipment (standard)

- Flap roof with 2 gas pressure dampers
- Tailgate with 2 gas tension dampers
- Reverse light
- Rear fog light
- Additional brake light
- Inner light
- Crank-support at the rear
- Tailgate with central locking
- Tie-down rings 6 pcs. (10 pcs.)

Special equipment

- Alloy-wheels
- Business package
- Anti-theft device
- Loading support
- Tray (15 cm depth)
- Motorcycle wheel chock
- 100 km/h allowance in Germany
- Spare wheel
- Breakdown set
- Vario-rail for bike-fixing
- Bicycle holder

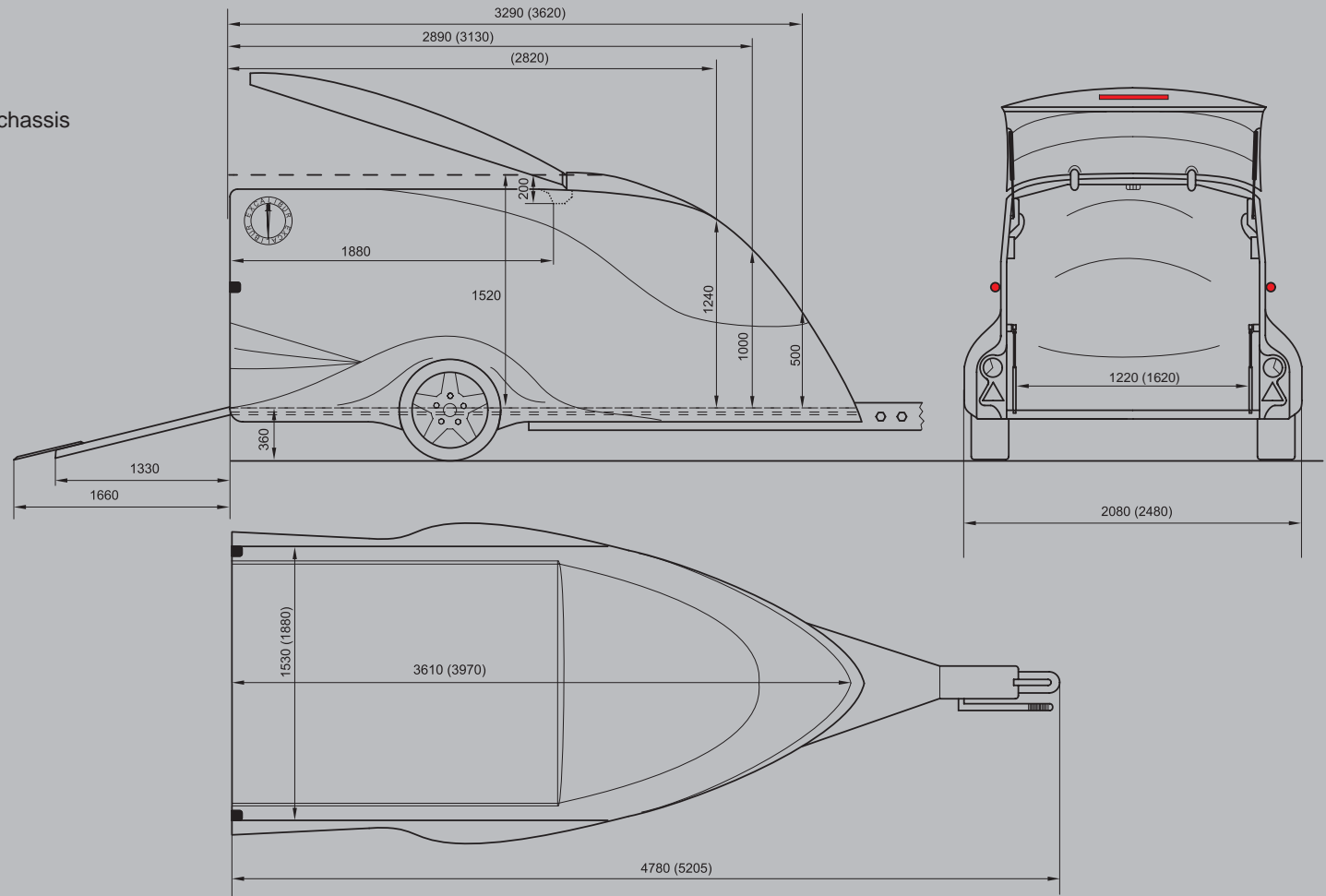

Measurements: S1 (S2)

Further options and individual painting on inquiry after check of feasibility. Extra costs will be charged.