



***Perfectness in Motion.***



***Excalibur***<sup>®</sup>  
← SPORT & BUSINESS CARRIER



*A wonderful couple with real attractiveness!*



**Excalibur**<sup>®</sup>  
SPORT & BUSINESS CARRIER

**No worries ...**

Made and developed for any kind of daily loadings, but showing up with an extra-ordinary design of the elegant and aerodynamic fiberglass body. The Excalibur transports any good dry and safe.

**... just carries!**

Using the Excalibur trailer for business purposes or just for fun - it is always an eye-catcher.



**Sports**  
**+**  
**Bikes**

The ultimate way to transport your goods. Whatever you transport, either a go-kart, a motorcycle or bike, or even a hot-air balloon - the Excalibur trailer takes all those items safe and protected.

**Products**  
**+**  
**Business**

Enjoy the additional benefit of that appealing travel companion as an ideal advertising medium - it is just unbeatable.

# Design and Colors!



Red White Grey Yellow

## Special colors



Silver-Metallic Black-Metallic Black Blue Customstyle

Two different sizes are available. For the measurements of the models S1 and S2, please, have a look at 'Technical Data'. Besides those options as brackets and clamps a business package with aluminium cover and integrated spare wheel holder is also available.

Type S1



Type S2

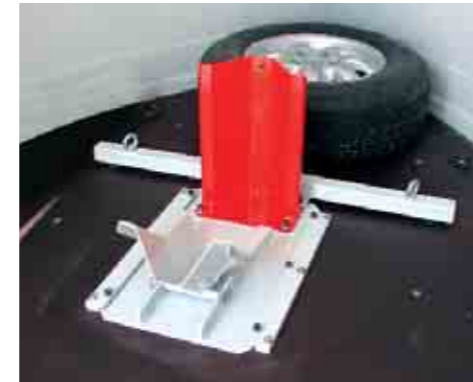

Motorcycle wheel chock



Tray for bikes higher than 150 cm

On inquiry we can offer further solutions to extend the usefulness of the trailer.



Business package with spare wheel



# Technical Data

## Body / Chassis:

Full fiberglass body

Frame:

Hot-dip galvanized AL-KO frame

Chassis:

Braked AL-KO axle with V-drawbar chassis

## Model:

Variant:

### Type S1

1300 (1500)

### Type S2

1500 (1800)

Length overall:

4780 mm

5205 mm

Length of body:

3610 mm

3970 mm

Width:

2080 mm

2480 mm

Height:

1970 mm

1990 mm

Net weight:

450 (460) kg

550 (570) kg

Gross weight:

1300 (1500) kg

1500 (1800) kg

Tyres:

205/70-14

205/65-15

(205/65-15)

(195/70-15)

## Equipment (standard)

- Flap roof with 2 gas pressure dampers
- Tailgate with 2 gas tension dampers
- Reverse light
- Rear fog light
- Additional brake light
- Inner light
- Crank-support at the rear
- Tailgate with central locking
- Tie-down rings 6 pcs. (10 pcs.)

## Special equipment

- Alloy-wheels
- Business package
- Anti-theft device
- Loading support
- Tray (15 cm depth)
- Motorcycle wheel chock

- 100 km/h allowance in Germany
- Spare wheel
- Breakdown set
- Vario-rail for bike-fixing
- Bicycle holder

Further options and individual painting on inquiry after check of feasibility. Extra costs will be charged.

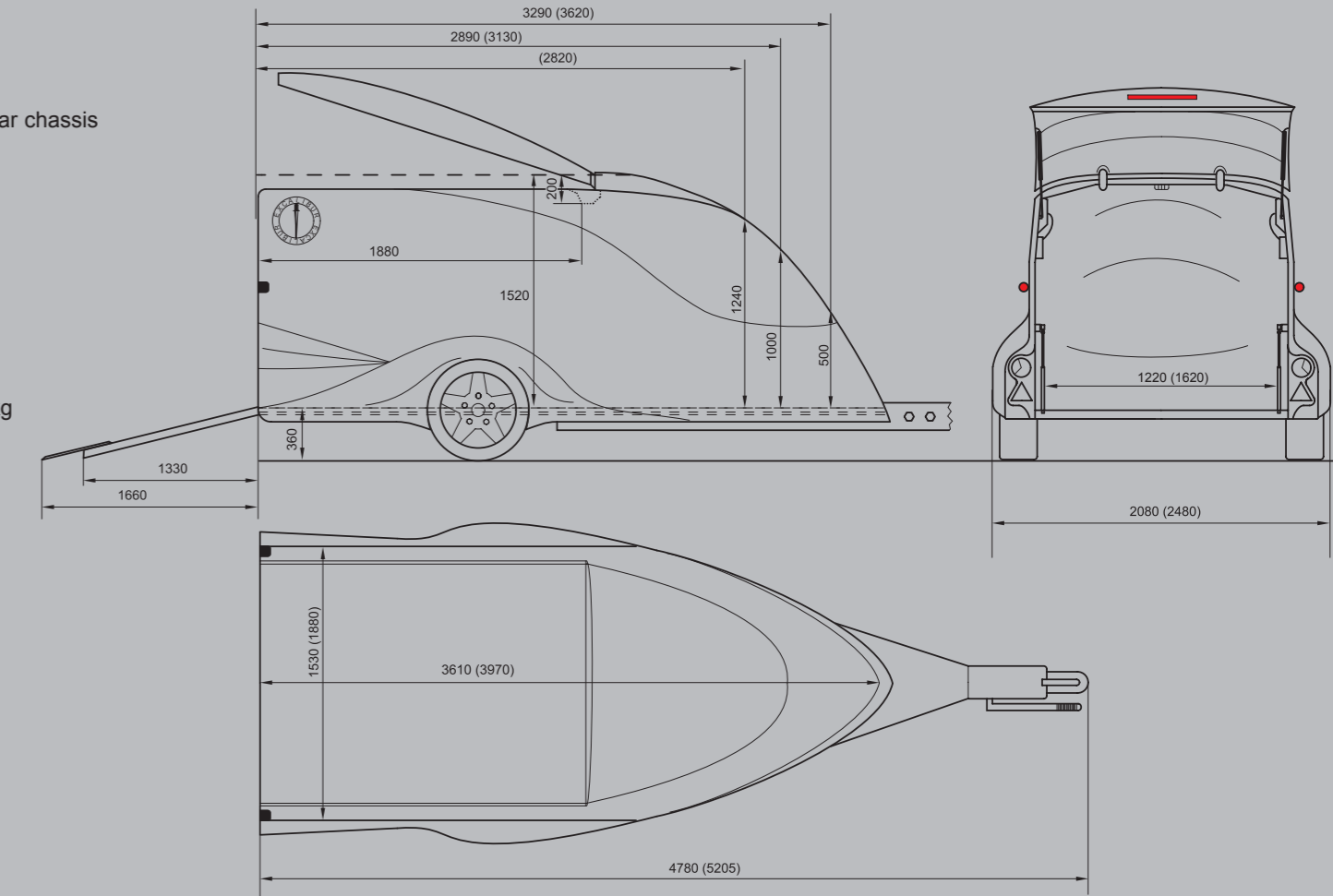

Measurements: S1 (S2)

# Just load 'n go!



The large tailgate and the flap roof allow easy access. The trailer also has superb handling qualities.

All information, photos, and technical details in this brochure are based on the latest stage prior printing. All rights to change technical and optical features are reserved.

Your Excalibur Dealer

**CONNECT THE BEAUTY  
WITH THE USEFUL.**



**Excalibur**<sup>®</sup>  
— SPORT & BUSINESS CARRIER —

D\*SIGN Dienstleistung- und Warenvertriebs GmbH • Schlosserstrasse 24 • D-51789 Lindlar  
Telephone +49(0) 2266/47999932 • Fax +49(0) 2266/47999929 • [www.ExcaliburEurope.com](http://www.ExcaliburEurope.com) • [info@ExcaliburEurope.com](mailto:info@ExcaliburEurope.com)